



Phenotypic variability in a family with a new SHOX gene mutation

Adalgisa Festa¹, Anna Grandone¹, Caterina Luongo¹, Emanuele Miraglia del Giudice¹, Giuseppina Rosaria Umamo¹, Alessandra Vottero², Roberta Minari², Laura Perrone¹

¹Department of Woman, Child, General and Specialized Surgery, Second University of Naples, Naples, Italy, ²Department of Clinical and Experimental Medicine, University of Parma, Parma, Italy.

Background

The spectrum of SHOX-related haploinsufficiency disorders ranges from Leri-Weill syndrome, characterized by short stature, mesomelia and Madelung deformity, to mild forms of disproportionated short stature, including also cases of so called “idiopathic short stature”. The phenotype of SHOX aploinsufficiency is highly variable also in affected members of the same family with broad differences in severity of short stature, disproportion, presence of Madelung deformity. In preschool age the phenotype can be nonspecific, with only short stature and with typical features developing later in childhood or adolescence.

Case presentation

We present a family with a new mutation of SHOX gene. A 2.3 years old girl, born at 38 weeks with normal birth weight and length from unrelated parents, came to our observation for short stature.

At the first visit her height was -2.02 SDS, arm span was normal, sitting height/ height was +1.3 SDS, she had cubitus valgus. Target height was -1.7 SDS; in particular her mother's height was -3.1 SDS, sitting height/height +3.7 SDS; cubitus valgus, Madelung deformity and mesomelia were present.

SHOX gene analysis, performed on the basis of mother's phenotype, revealed an **heterozygous nonsense mutation (c.382C>T p. Gln 128Ter)** both in the proband and in her mother.

The same mutation was found in other four related adults and three children: clinical features of affected family members are shown in table 1.

Discussion

According to others (1,2) a remarkable phenotypic variability is seen in affected members carrying the same mutation also in the same family, probably related to background genetic effects, intragenic not individuated mutations, environmental factors and epigenetic effects.

In our family some different degrees of clinical expression of SHOX aploinsufficiency coexist:

the proband's mother shows a Leri-Weill syndrome phenotype (IV) 10 fig. 1), the grandmother (III)4 fig. 1), although presenting the most impaired stature, does not present Madelung deformity or other typical clinical stigmata; patient IV)11 (fig 1) has a normal stature, regular body proportion and only bilateral tibial bowing as clinical manifestation of mutation, despite her daughter (V)4 fig.1) presents a Leri-Weill syndrome phenotype. The severity of short stature seems to be more pronounced in adults than children, in accordance with literature (2,3).

Sitting height/height ratio appears the most represented anthropometric alteration in affected members of our family, regardless from age and short stature severity (2).

The novel mutation found (c.382C>T p. Gln 128Ter) affects the highly evolutionary conserved aminoacid in the homeodomain of SHOX protein producing a premature stop codon. To date 2 missense mutation in the same position have been reported in literature cosegregating with Leri-Weill syndrome phenotype (1).

This mutation is likely to impair SHOX function leading to a truncated protein, involving the DNA binding homeodomain, essential for transcriptional activity of SHOX, with consequent aploinsufficiency of gene.

In preschool years SHOX defects related phenotype can be silent and a careful clinical and anthropometric evaluation of parents is useful for diagnosis.

In our family clinical expression of SHOX aploinsufficiency is highly variable but almost all affected patients show increased sitting height/height ratio.

This confirms the usefulness of sitting height/height ratio, expressed in SDS for age and sex, as an index of suspicion for SHOX aploinsufficiency.

Picture 1. genealogical tree of our family

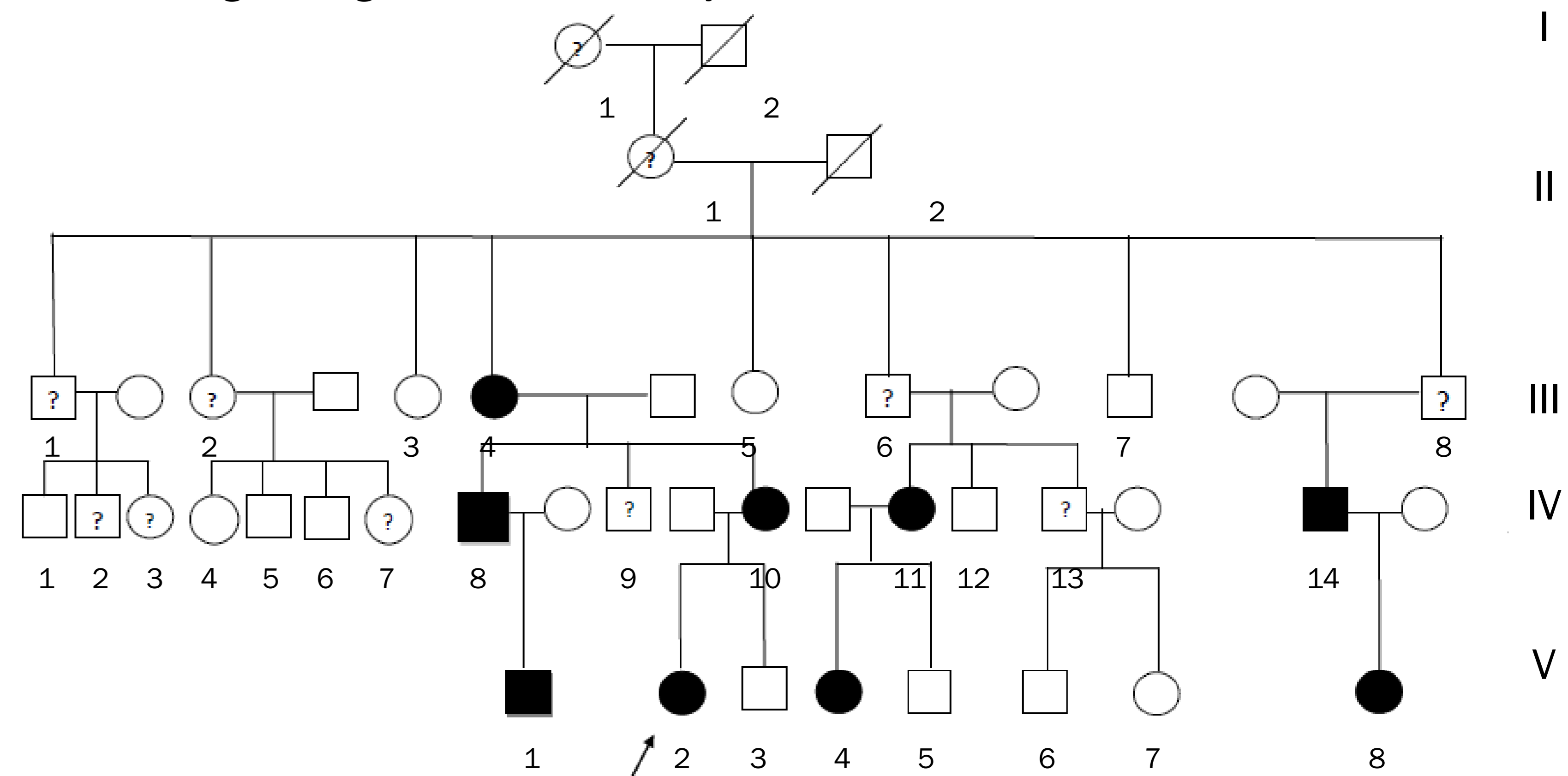

Legend: filled symbols affected subjects; symbols with ? subjects not tested but clinically suspected

Table 1. Clinical features of affected members.

Patient (sex)	III)4 (F)	IV)8 (M)	IV)10 (F)	IV)11 (F)	IV)14 (M)	V)1 (M)	V)2 (F)	V)4 (F)	V)8 (F)
Age(ys)	70	41	36	39	40	4 ys 4/12	3 ys 8/12	14 ys 5/12	8 ys 3/12
Height SDS	-3.9	-3.1	-3.08	-1.58	-2.5	-1.46	-2.06	-2.08	-2.04
Sitting Height % (DS)	---	0.55 (+2.97)	0.57 (+3.7)	0.52 (-0.3)	0.56 (+3.7)	0.60 (+3.5)	0.59 (+2.3)	0.55 (+2.7)	0.57 (+3.5)
Armspan/height	1.03	1.08	0.97	0.98	1.03	1.01	0.97	0.96	0.98
Arched palate	no	no	no	no	no	yes	no	no	yes
IV metacarpal brevity	no	yes	yes	no	no	no	yes	yes	yes
Madelung deformity	no	yes	yes	no	no	no	no	yes	no

References

1. Grigelioniene G. et al. (2001) Analysis of short stature homeobox-containing gene (SHOX) and auxological phenotype in dyschondrosteosis and isolated Madelung deformity. Hum Genet 109:551-558
2. Jorge AA. et al. 2007. SHOX mutations in idiopathic short stature and Leri-Weill dyschondrosteosis: Frequency and phenotypic variability. Clin Endocrinol (Oxf) 66:130-135.
3. Binder G: Short stature due to SHOX deficiency: genotype, phenotype, and therapy. Horm Res Paediatr 2011, 75:81-89.

This work was carried out with the unconditional support of Eli-Lilly