

Testosterone levels in newborn boys and girls related to penile length, Anogenital Distance (AGD) and External Genitalia Score (EGS)

Jon Sigurdsson, Inga Bartuseviciene, Anna Nordenström

Dept of Pediatric Endocrinology, Astrid Lindgren Children's Hospital, and the Clinical Laboratory, Karolinska University Hospital, Stockholm, Sweden.

Department of Women's and Children's Health, Karolinska Institutet, Stockholm, Sweden

Conclusion

- Testosterone levels were, as expected, significantly higher in the boys. The ECLIA method gave testosterone varying between 2.0 and 7.8 in the girls, most likely due to cross reactivity with adrenal metabolites. The LC-MS/MS method gave considerably lower measurements.
- Knowledge on the normal levels of testosterone in the neonatal period is essential and valuable for adequate evaluation when assessing newborns with genital ambiguity.

Objectives

- To measure testosterone in serum of newborn boys and girls.
- To obtain reference values of importance in the hormonal evaluation of a newborn with ambiguous genitalia.
- To see if genital masculinisation could be related to the testosterone levels in boys and girls respectively.

Background

- Testosterone levels in newborns are changing over the first weeks of life. This dynamic change is making the assessment of infants with ambiguous genitalia complicated.
- The Clinical laboratory at Karolinska offer two different methods for measurement of serum testosterone; ECLIA (electrochemiluminescence immunoassay) and Liquid chromatography–tandem mass spectrometry (LC–MS/MS).
- It is important to evaluate these two methods in the neonatal period and the use of them in the diagnostic work-up in newborns with atypical genitalia or genital ambiguity.
- In literature AGD measurements show a positive correlation with weight, length and gestational age. The anogenital ratios (AGD as/ap and AGD af/ac) are possible independent of body size and gestational age. Then the anogenital ratio can be useful as a sensitive index of androgen action in early fetal development in both premature and full-term female infants.

Method

- Testosterone was analysed using two methods: ECLIA and LC–MS/MS. Blood sample were obtained from 45 full-term babies, at the same time as the neonatal screening sample, day 2-3.
- Clinical data in 100 babies for penile and clitoris length, "External Masculinization Score" (EMS), "External Genitalia Score"(EGS) and Ano-genital distances (AGD) were collected using digital calipers. AGDas: anus to posterior base of scrotum, AGDap: to anterior base of penis, AGDaf: to fourchette, AGDac: to anterior base of clitoris.

Males(N=52)

Mean (mm)
AGDas 23.6 (17.5 – 30.7)
AGDap 44.8 (37.2 – 53.1)
AGD ratio(as/ap) 0.53 (0.44–0.68)

Females(N=48)

Mean (mm)
AGDaf 15.6 (11.1 – 21.3)
AGDac 36.3 (30.9 - 43.8)
AGD ratio(af/ac) 0.43 (0.29–0.55)

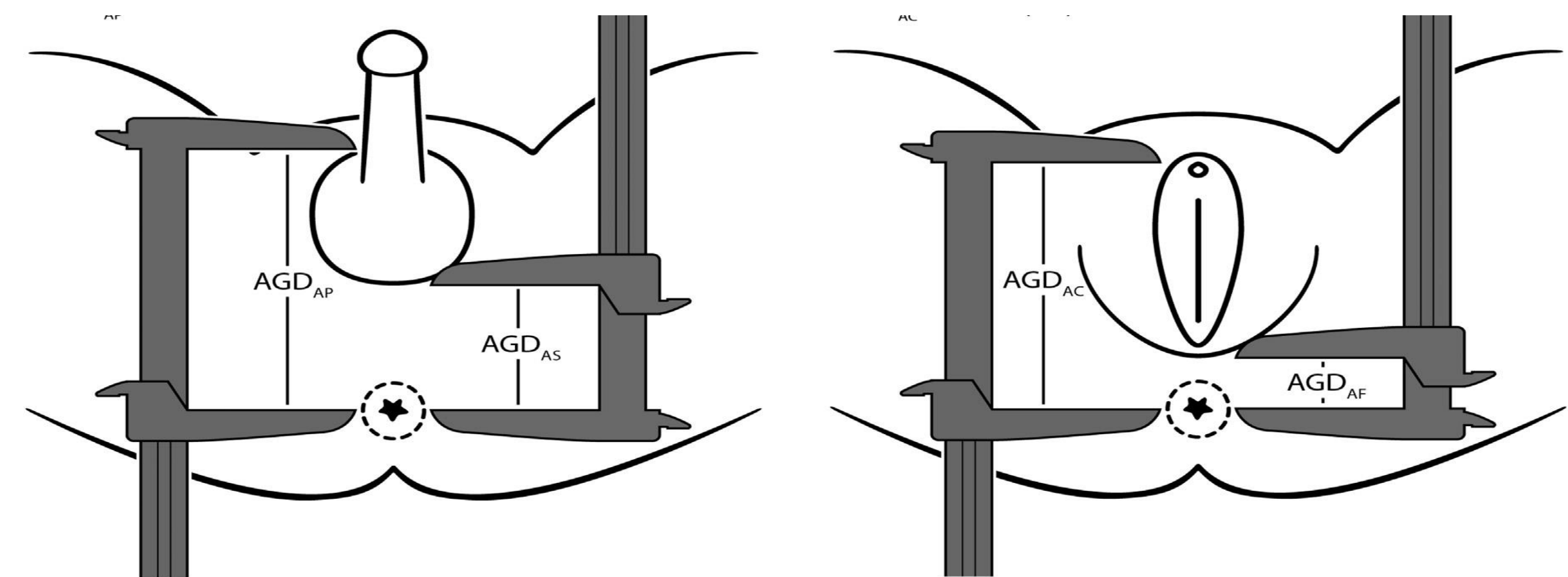

Fig 1. Anogenital distance measurements and values

Results

Sex	N	Testosteron (ECLIA) nmol/L	Testosteron (LC-MS/MS) nmol/L
Male	20	7,5(4,8-15,0)	
	22		1,9(0,3-4,9)
Female	24	5,1(2,0-7,8)	
	23		0,2(0,1-0,6)

Table 1. S-testosterone measurements with ECLIA and LC-MS/MS in newborn infants at the age 2-3 days

Sex	N	GA (w) (mean)	BW (g) (mean)	Maternal age (year) (mean)	EMS score (mean)	Penile length (mm) (mean)	EGS score (mean)	AGD ratio (mean)
Male	52	39,5	3571	30	12	31,93 (2,15-4,15)	11,8 (11,5-12)	0,53 (as/ap)
Female	48	39,3	3388	30	0		0	0,43 (af/ac)

Table 2. Birthdata of the infants, penile length, EMS-score, EGS-score and anogenital ratio

- Correlation between the two testosterone methods was moderate positive ($r= 0,55$)
- There was no correlation between penile length and testosterone, neither method
- AGDas/ap had no correlation with testosterone, but there was a low negative correlation between AGDaf/ac and testosterone with the ECLIA method ($r= -0,44$) and no correlation with the LC-MS/MS method ($r= -0,25$)

Karolinska University Hospital, Dept of Ped. Endocrinology, Astrid Lindgren Children's Hospital Stockholm, Sweden
Jon Sigurdsson
E-mail: jon.sigurdsson@sll.se

KAROLINSKA
Universitetssjukhuset



Karolinska
Institutet

